

POWERED by
LONCIN

MOTORE 4 TEMPI - ENGINE 4 STROKE

Modello Model	Potenza nominale Rated power	Coppia massima Max. torque		Sistema avviamento Starting system	Cilindrata Displacement	Carburante Fuel
type	3600 r.p.m.	Nm	rpm	type	cc	type
Monocilindrico, raffreddamento ad aria, 4 - tempi Single cylinder, forced air cooling, 4 - stroke	5,2 kW	15,2	2800	manuale - elettrico recoil - electric	252	Benzina Gasoline

Capacità serbatoio Tank capacity	Capacità serbatoio olio Oil tank capacity	Rumorosità Noise	Alesaggio corsa Bore Stroke	Dimensioni Dimensions	Peso a secco Dry weight
lit	lit	≤7m dB (A)	mm	mm	Kg
4	0,7	70	75 x 57	365 x 285 x 370	16,5

VERSIONE / VERSIONS



Albero conico D.23
Cilindric shaft

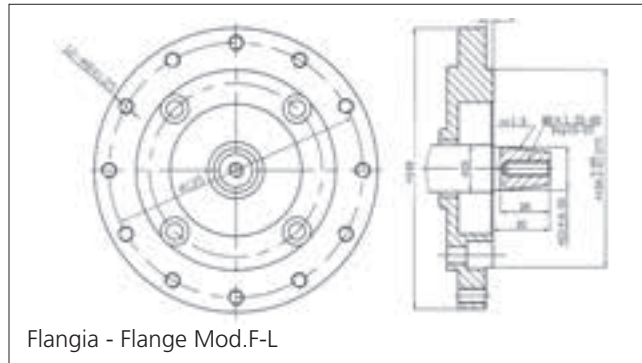

Flangia - Flange Mod.F-L

G 252 F-L

- Albero Conico D.23
- Avviamento Manuale
- Filtro Aria bagno olio



Albero cilindrico D.25,4
Cilindric shaft

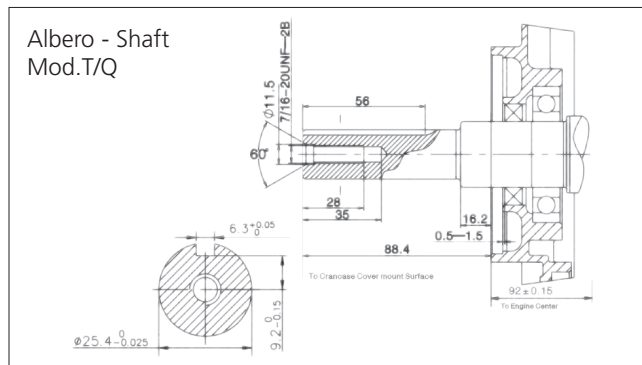

Albero - Shaft
Mod.T/Q

G 252 F-T/Q

- Albero Cilindrico D.25,4
- Avviamento Manuale
- Filtro Aria a secco



Albero cilindrico D.25,4
Cilindric shaft

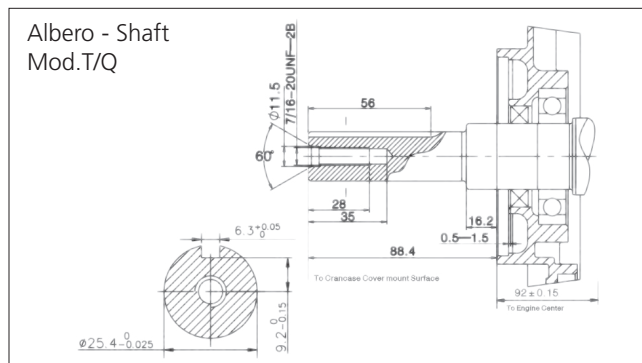

Albero - Shaft
Mod.T/Q

G 252 FD-T/Q

- Albero Cilindrico D.25,4
- Avviamento Elettrico
- Filtro Aria a secco



Albero lungo generatore
Generator shaft

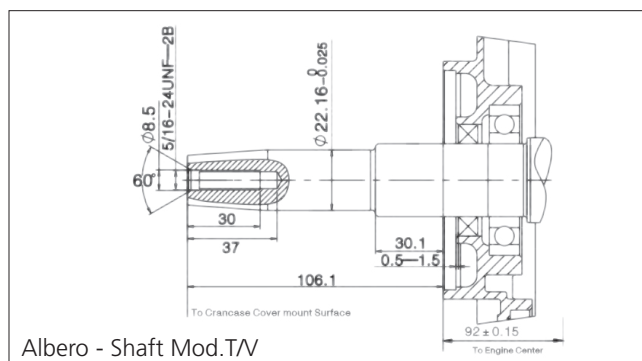

Albero - Shaft Mod.TV

G 252 F-TV

- Albero lungo generatore
- Avviamento Manuale
- Filtro Aria a secco